

SCOOTER **GENUINE** COMPANY

OWNER'S MANUAL

Stella

- IMPORTANT INFORMATION FOR THE CARE AND MAINTENANCE OF STELLA

Dear Customer,
 This is **IMPORTANT INFORMATION**

<p>1. Name :</p> <p>Address :</p> <p>.....</p> <p>City :</p> <p>State : Zip Code :</p> <p>Licence No :</p>	<p>3. Your Stella</p> <p>Colour :</p> <p>Engine No. <table border="1" style="display: inline-table; border-collapse: collapse;"><tr><td>E</td><td>1</td><td>7</td><td>3</td><td></td><td></td><td></td><td></td><td></td><td></td></tr></table></p> <p>Chassis No. <table border="1" style="display: inline-table; border-collapse: collapse;"><tr><td>M</td><td>D</td><td>7</td><td>C</td><td>G</td><td>8</td><td>4</td><td>A</td><td></td><td></td></tr><tr><td></td><td></td><td>3</td><td></td><td></td><td></td><td></td><td></td><td></td><td></td></tr></table></p> <p>Key No. :</p> <p>Date of purchase :</p> <p>Date of Registration :</p>	E	1	7	3							M	D	7	C	G	8	4	A					3							
E	1	7	3																												
M	D	7	C	G	8	4	A																								
		3																													
<p>2. Your Genuine Dealer</p> <p>Name :</p> <p>Address :</p> <p>.....</p> <p>City :</p> <p>State : Zip Code :</p> <p>Tel. No. :</p>																															

C-4727090 : STELLA-USA. : (E)

We at **Genuine Scooter Company** thank you for choosing *Stella* as your new scooter.

Stella's classic frame is instantly recognizable, and the manual transmission always keeps you in control. Stella offers the comfort of a new scooter, the security of time-tested engineering, and is collectable "right out of the box."

With the turn of a key, Stella's auto thumb-start gets you going instantly. The 5-port Automatic Oil Mixing (AOM), 150cc Engine with Catalytic Converter and Reed Valve Induction, has the power to deliver 8+/-0.3 BHP at 5500+/-200 RPM.

Stella is sure to offer smooth performance and years of comfortable riding. It's style, performance, and metallic colors are impossible to ignore.

This owner's manual has been designed to help you understand Stella. To optimize her performance and life, please go through this manual thoroughly.

CAUTION : Removal of the catalytic converter is a violation of Federal law and will render the warranty null and void.

CONTENTS

DESCRIPTION	PAGE NO.	DESCRIPTION	PAGE NO.
Reporting Safety Defects	4	Recommended oil & Lubricants	28
General specifications	5	Maintenance	29
Identification data	7	Removal of cowls	29
Performance & Specifications	8	Tuning of carburettor	30
Specifications (Auto start)	12	Dismantling air cleaner & air filter	30
Fuel supply	13	Spark plug cleaning	31
General Instructions	17	Changing oil in gear case	32
Locking System	17	Dismantling cooling hood & cyl. head	32
Glove compartment	18	Changing wheels & tyres	33
Saddle lock	18	Removal & refitting of spare wheel	34
Instrument panel	19	Brake adjustment	35
Control switches	20	Front disc brake	36
Catalytic Converter	21	Replacing bulbs	37
Operating the vehicle	23	Head lamp setting	38
Engine Running-in	25	Periodical maintenance	39
Electrical equipments	26	Cleaning & polishing	41
Battery	26	Care of your vehicle when not in use	42
Wiring diagram (auto start)	27	Trouble shooting	43

2

Stella

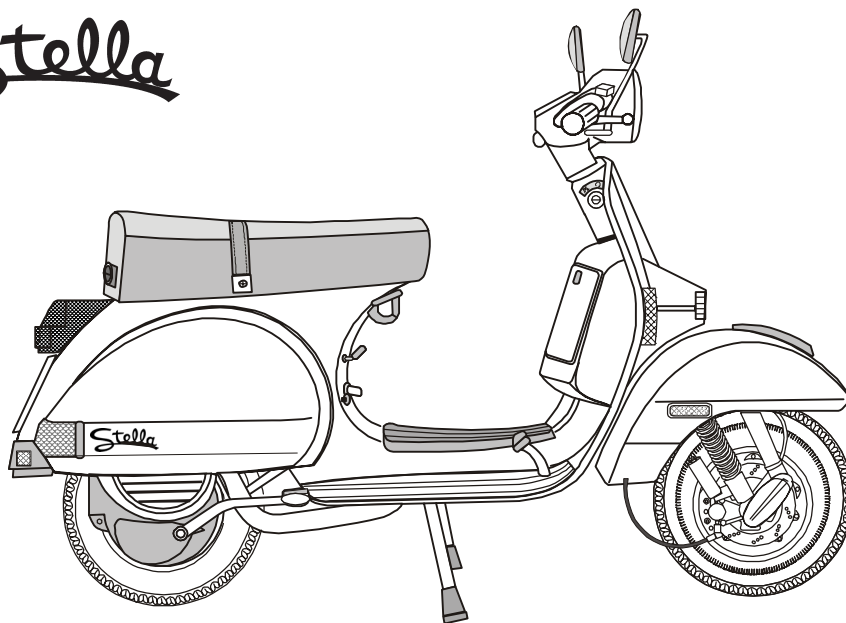

Genuine Scooter Company always recommends that you wear a helmet and protective eyewear when riding your scooter. BE SAFE!

3

CONSUMER INFORMATION

49 CFR 575.6

Genuine Scooter Company
5400 Damen Avenue
Chicago, Illinois 60625

Reporting Safety Defects

If you believe that your vehicle has a defect that could cause an accident, or could cause injury or death, you should immediately inform the National Highway Safety Administration (NHTSA) in addition to notifying Genuine Scooter Company, LLC.

If NHTSA receives similar complaints, it may open an investigation, and if it finds that a safety defect exists in a group of vehicles, it may order a recall and remedy campaign.

However, NHTSA cannot become involved in any individual problems between you, your dealer, or Genuine Scooter Company, LLC. To contact NHTSA you may either call the Auto Safety Hotline toll-free at 1-800-424-9393 (366-0123 in Washington, DC area) or write to :

NHTSA
U.S. DEPARTMENT of TRANSPORTATION
400 7th Street SW, (NSA-11)
Washington, DC 20590

You can also obtain other information about motor vehicle safety from the Hotline mentioned above.

4

GENERAL SPECIFICATIONS

Engine: A new generation energy saving and the cleaner burning engine is connected to the vehicle chassis through the crankcase swinging arm on the clutch side. The rear wheel (drive-wheel) is fitted on the outer side of the drive shaft.

Lubrication: Engine (piston, cylinder, crank shaft, main bearings flywheel side) is lubricated by an automatic oil mixer device (AOM).

Fuel supply: Gravity fed petrol and oil. Oil is mixed in petrol with automatic oil mixer device. Carburettor has a throttle slide, and the air intake is located under the seat.

Ignition: An electronic ignition device (CDI) feeds the current to a high voltage transformer (HT coil) to generate the spark.

Starting: For self start, push button on right hand side of handlebar below head light switch. For manual start, a kick start pedal is located on the right side of the scooter.

Cooling: Forced air provided by a centrifugal fan.

Clutch: A heavy duty, multi-plate oil bath type. The unit is cable operated by a lever located on the left side of the handlebar and is adjustable.

Gear box: Four speed forward drive with constant mesh gears immersed in oil bath are operated by hand on the left hand side of the handlebar which functions in conjunction with the clutch control lever.

Integral Chassis: Pressed steel sheet. Monocoque structure.

Wheels: Interchangeable and made out of pressed steel rim with 3.5 x 10 (89 x 254 mm) tires.

Handlebar: Aluminium casting base with headlamp, instrument panel and indicator lights. All transmission cables are concealed within the casting.

Steering column and suspension: The steering column is connected to the front wheel swinging hub. Front and rear suspensions are provided with helical spring and hydraulic dampers.

5

Security lock: On the steering column and operated by a key.

Saddle: Dual saddle, tip up type with push button control and key security lock.

Brakes: Cable operated drum brakes with dual expanding shoes.

Front Brake: Operated by hand lever placed on right hand side of handle bar.

Rear Brake: Operated by pedal on the right hand side footboard.

Rear view mirror: Stylish rear view mirrors on both side of handle bar.

Glove compartment: A sleek & spacious glove compartment for keeping personal belongings etc. secured with a lock.

Hook for Bag : Hook under the seat for hanging a bag or helmet.

Foot mat: Moulded centre mat & floor channel, which protect entire foot rest area.

Battery : 12 Volt 9Ah battery.

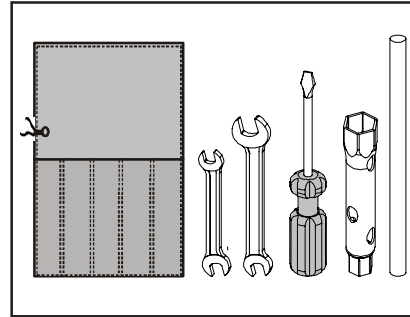

Fig. 1

5. Tool kit:

Pouch containing:

Box wrench (13 X 21mm) and lever

Double sided screwdriver

2 double ended wrenches

(7 x 8 mm and 8 x 11 mm)

VEHICLE IDENTIFICATION

The vehicle is identified by two numbers: one number is on the chassis and another is on the engine.

The chassis identification number is stamped on the right side of rear portion of the chassis frame (fig. 2). The first row of this number will be MD7CG84A-- and the second row will have 8 characters.

MD7CG84A-- and the second row will have 8 characters.

The engine number is stamped on the crank case (fig. 3) and will have the prefix E17-- followed by 8 characters.

Each *Stella* scooter comes with one set of duplicate keys; both keys are stamped with identification number. Remember where you place your duplicate key.

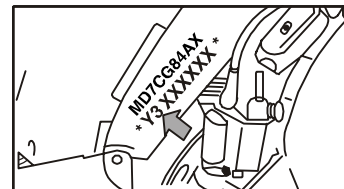

Fig. 2

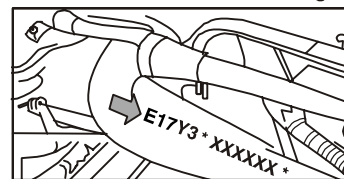

Fig. 3

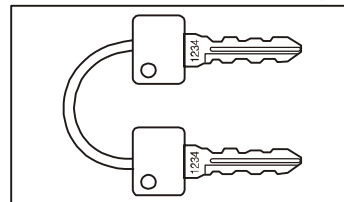

Fig. 4

PERFORMANCE & SPECIFICATIONS

Dimensions

Overall length	5.77 feet 1760 mm
Overall width	2.28 feet 695 mm
Wheel base	4.05 feet 1235 mm
Maximum road clearance	0.52 feet 160 mm
Seat height	2.69 feet 820 mm

Weights

Vehicle dry weight	240 lbs 109 kg
Maximum technically permissible mass	595 lbs 270 kg

Engine

	Single cylinder, two stroke, forced air cooled with rotary distribution with 5 transfer ports and reed valve induction with catalytic converter.
Displacement	149.56 cc
Bore	2.27 inch 57.8 mm
Stroke	2.24 inch 57.0 mm
Compression ratio	9.0 ± 0.5 : 1
Maximum output/Power	8 ± 0.3 bhp @ 5500 ± 200 RPM
Maximum torque	13.5 Nm @ 3500 RPM
Ignition system	Capacitor Discharge Ignition (CDI) Electronic
Ignition timing	20° ± 2° before TDC

8

Fuel

	Un-leaded 87 octane Petrol with automatic mixing of 2T oil
Fuel tank capacity	2.1 US Gallon (inclusive of 0.26 gallon in reserve.)
Oil tank capacity	0.26 gallon
Fuel cock	Three way tap. Open (ON); Close (OFF), Reserve (RES).
Carburettor	SPACO -20/20D, Downdraft, 20mm venturi
Spark plug	RN9YC - Champion, B6ES - NGK, WR6DC - Bosch
Spark plug gap	0.7-0.8 mm
Starting	Push button for auto start & kick pedal for manual start.
Clutch	Multiplate, oil bath type.
Transmission	4 speed constant mesh
Overall Gear Ratio	
1st Gear	15.38:1
2nd Gear	10.46:1
3rd Gear	7.24:1
4th Gear	5.39:1

9

Chassis

Steering column and suspension

Pressed steel sheet, monocoque structure

The steering column is connected at the front lwheel swinging hub.

Front & rear suspension

Front and rear suspension with helical spring and hydraulic dampers.

Brakes

Front brake

Disc brake

Rear brake

Drum brake, mechanical expanding shoe type

Tires

Front and rear tires

3.50 x 10" (89 x 254 mm) 4 Ply rating, interchangeable

Tire pressure

Front wheel

22 psi *varies with

Rear wheel

29 psi temperature

Controls

Steering

By Handlebar

Accelerator

Twist grip type on right hand side of the handlebar

Gears

By hand on left hand side of the handlebar

Clutch

Lever operated on left hand side of the handlebar

Front brake

Lever operated by right hand

Rear brake

Pedal operated by right foot

10

Electricals

Generator system

12 Volt 96 Watt flywheel magneto

Head lamp

12 Volt 35/35 Watt

Front position lamp

12 Volt 5 Watt

Tail light

12 Volt 5 Watt

Stop light bulb

12 Volt 10 Watt

Speedolight bulb

12 Volt 1.2 Watt x 2

Turn signal light bulb

12 Volt 21 Watt

Tell tale lamp

12 Volt 1.2 Watt x 6

Horn

12 Volt DC Horn

Battery

12 Volt 9 Ah

Fuse

8 Amp

Maximum speed

53 mph in 4th Gear

11

SPECIFICATIONS

(Auto start)

Stella has an auto push button start located just below the turn signal light switch (fig.5), as well as an optional kick-start. The auto start circuit is operated by a 12 volt-9Ah battery.

A **PRD** relay (**P**revention of **R**estarting **D**evice) is provided to avoid use of the self-starter when the engine is running.

A **declutch switch** has been provided to prevent starting of scooter when the clutch is engaged.

An **8 Amp fuse** (Near spare wheel bracket, rear side fig. 6 & 7) is provided to avoid any damage due to short circuiting in auto start system.

A powerful **12 volt-96 watt magneto** charges the battery through a regulator with a built in charger.

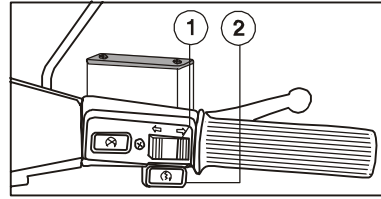

Fig. 5

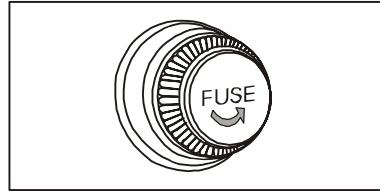

Fig. 6

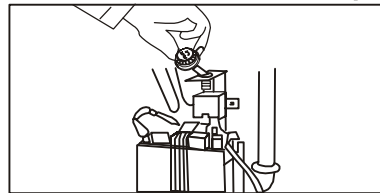

Fig. 7

12

Fuel supply: Both the fuel tank and oil tank are located under the saddle (fig. 8) and are accessible only when the saddle is unlocked and lifted.

Stella scooters are produced with AOM (Automatic Oil Mixer) for engine lubrication, and therefore have two separate tanks, one for petrol 'A' and the other for 2T oil 'B' (fig. 9).

Do not fill tank 'A' with "petrol oil mixture". Only pure petrol is to be filled in tank 'A'. The oil tank 'B' should only be filled with 2T motor oil.

*Ask your dealer for recommendations about brands.

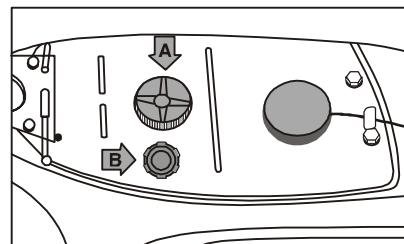

Fig. 8

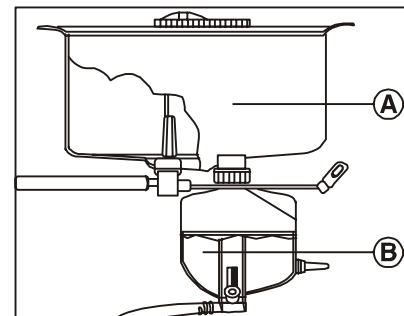

Fig. 9

13

The petrol is fed to the carburetor by a normal gravity system. The oil is supplied in the suction pipe by means of an AOM device 'M' (fig. 10) comprising of a piston pump with variable stroke. This is controlled by crank shaft through a gear transmission.

The oil tank is provided with a transparent cup 'C' (fig. 11) for checking oil level, which normally remains full of oil. When oil level lowers to reserve value, air bubbles will appear in the cup. Refill recommended 2T Motor Oil.

Note: Take care that the oil inlet pipe 'T' (fig. 10) from oil tank to the 'AOM' device is completely full of oil. If air bubbles are present, take off the pipe 'T' from the 'AOM' device, let some oil flow out so that the air bubbles are eliminated. Reconnect the pipe.

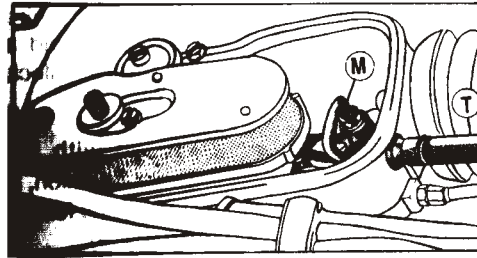

Fig. 10

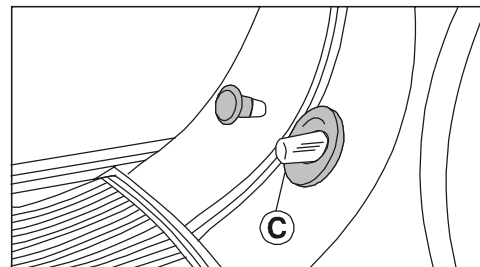

Fig. 11

14

Petrol control (fig. 12): The fuel cock below the saddle has 3 positions. Use (ON) for regular flow of petrol from tank to the engine; (OFF) for stopping the petrol supply to engine; and (RES) i.e. Reserve, to access the one litre of petrol kept in reserve in your tank for emergencies.

Choke knob (fig. 13): Located below the seat. To be used for starting the engine when it is cold. Pull the choke knob outwards for operation. It should be pressed back when the engine has started running.

Caution: If the choke knob remains pulled out during running, it will lead to the flooding of petrol in the carburetor causing erratic running and high fuel consumption.

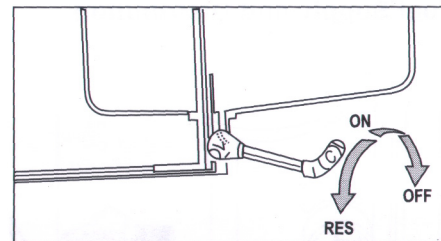

Fig. 12

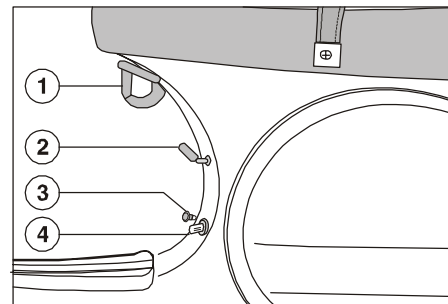

Fig. 13

- 1. Hook for bag
- 2. Fuel cock
- 3. Choke knob
- 4. Oil level indicator

15

Fuel Supply and Distribution

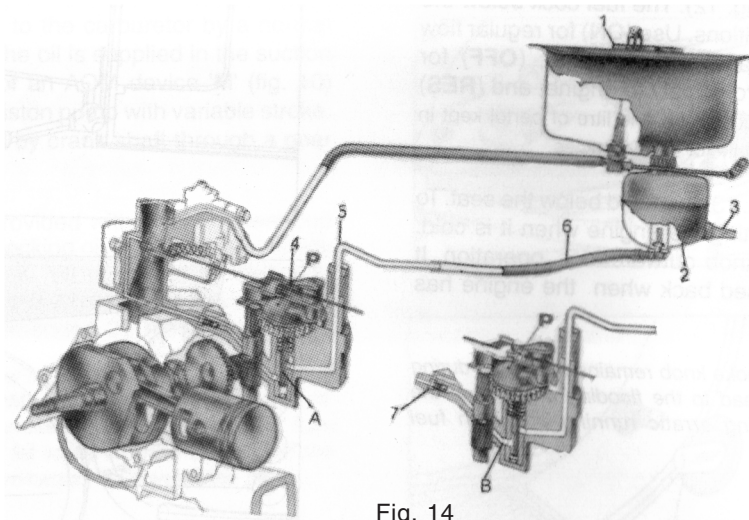

Fig. 14

- | | | |
|------------------------|--------------------|---------------------|
| 1. Petrol tank cap | 4. 'AOM' Device | 7. Oil supply valve |
| 2. Oil tank cap | 5. Oil inlet pipe | A. Suction period |
| 3. Oil level indicator | 6. Oil supply pipe | B. Delivery period |

16

LOCKING SYSTEM

The same key that starts *Stella*, also locks the steering column, glove compartment and saddle.

Locking the Handlebar: First turn the handlebar to the extreme left and then turn the key anticlockwise to lock position. Pull out the key after locking (fig. 15).

Un-locking the Handlebar: To unlock, insert key in the ignition, and turn clockwise.

To switch on the ignition: Turn the key further clockwise to 'ON' position (fig. 16).

Caution:

As soon as ignition key is switched 'ON', the tail lamp and position lamp is turned 'ON' and brake lamp, flasher and horn are operable. These loads are operable on battery. Battery would be discharged considerably if ignition key kept 'ON' for more than 5 minutes when vehicle is in static condition (without engine running).

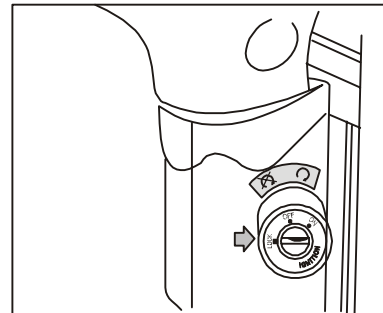

Fig. 15

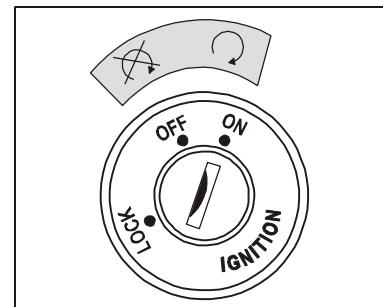

Fig. 16

17

Glove compartment lock: To open the glove compartment, insert the key into the lock, turn it completely counterclockwise, and then press it downwards (fig. 17).

To lock, press lid and turn the key clockwise.

Saddle Lock: To unlock, Insert the key and turn it clockwise to end.

To open, push lock in with thumb, and lift the saddle from the back.

To close, press the saddle to its normal position: turn the key counterclockwise to lock.

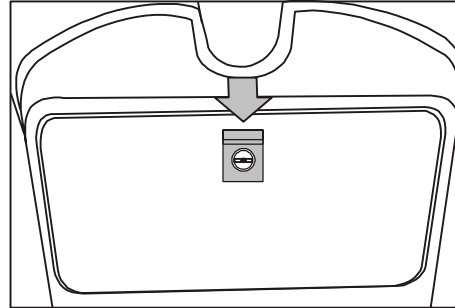

Fig. 17

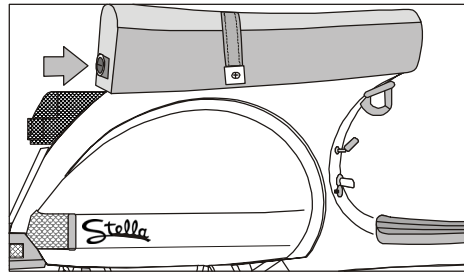

Fig. 18

INSTRUMENT PANEL

An elegantly designed instrument panel with the following indicators.

1. Head light high beam indicator
2. LH turn signal indicator
3. Neutral indicator
4. Speed indicator needle
5. Odometer
6. Stop indicator
7. RH turn signal indicator
8. Head light low beam indicator
9. Fuel-gauge

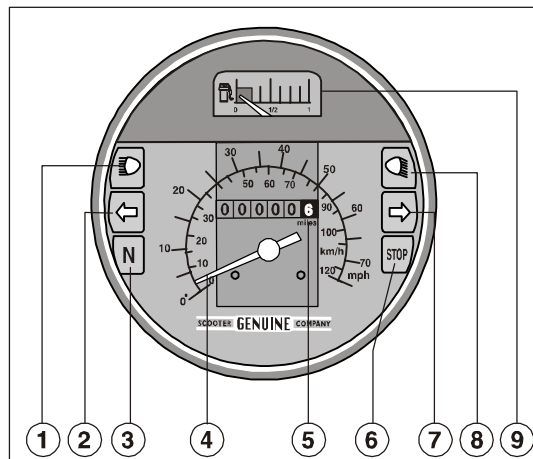

Fig. 19

CONTROL SWITCHES: Control switches are located on the left and right hand sides of the handlebar.

Left hand side of the handlebar (fig. 20) :

Headlight : Headlight becomes operative while starting the engine.

For high beam press top end of switch '2', and for low beam press bottom end.

Headlight high & low beam positions are indicated on the instrument panel.

Stop light : Becomes operative when foot brake pedal or hand brake lever is pressed.

Stop light indicator is shown on the instrument panel.

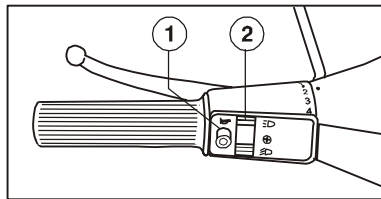

Fig. 20

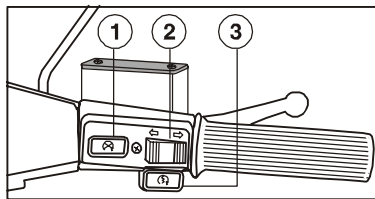

Fig. 21

Horn : Press button '1' (fig. 20).

Right hand side of the handlebar (fig. 21).

Turn indicator switch : Press left end of switch '2' for turning left, and right end for turning right.

For auto start : First press in clutch lever, then press the start button '3'.

Left & right turn indicator is shown on the instrument panel.

Engine kill switch : To stop engine press switch '1'.

Neutral Switch : Is provided in gear control bracket & neutral indicator is shown on the instrument panel.

CATALYTIC CONVERTER

The Catalytic converter is an emission control device used to convert toxic gases (Carbon Monoxide, Hydrocarbons and oxides of Nitrogen) into Eco-friendly gases (Carbon dioxide, water vapour and Nitrogen) so as to reduce the air pollution from the exhaust gases.

These vehicles are identified with an rectangular sticker near the fuel tank mouth as a reminder to 'USE UNLEADED PETROL ONLY'.

Caution : Removal of the catalytic converter is a violation of Federal law, and will render the warranty null and void.

To make your Catalytic converter last longer.

1. Use **ONLY UNLEADED PETROL** in the fuel tank.
2. Use **ONLY quality 2T OIL (Two Stroke).**

A rectangular sticker 'USE RECOMMENDED OIL ONLY' is pasted on the fuel tank.



2. To get best out of your vehicle fitted with Catalytic Converter.
 - 2.1 Keep the engine properly tuned.
 - 2.2 Do not switch off the engine abruptly when the transmission is engaged and vehicle is in motion.
 - 2.3 Do not drive the vehicle with choke knob pulled.

Precautions :

Since the silencer fitted with Catalytic converter can be extremely hot during running of vehicle. do not touch the silencer to avoid serious burns.

OPERATING THE VEHICLE

Warning: Before driving your scooter make yourself thoroughly familiar with all operating controls and their functions.

Before starting the engine:

Check if tires are properly inflated.

Check for correct play in the clutch lever and make sure that it operates properly.

Check for correct play in the foot brake pedal and hand brake lever.

Check if the accelerator throttle is operating properly and if the play is normal.

Ensure that 2T oil is available in the oil tank, taking the reference of oil level indicator.

Starting the engine (fig. 22)

Open fuel cock to "ON" position.

Turn "ON" the Ignition switch.

Put gear control in neutral position & ensure indicator on instrument panel is ON.

Pull out the choke knob (for cold engine start only.)

Bring the throttle to idling position

If you are starting engine for the first time in the day, press the clutch lever and, keeping it pressed, kick the starter pedal a couple of times.

For starting the engine press clutch lever and then press the push button start switch.

When the engine is running normally, press the choke knob back to its normal position.

Caution:

1. Do not use electric starter for more than 5 seconds at a time. Release the push button start switch for approximately ten seconds before pressing it again. If the engine fails to start after repeated attempts hold the throttle 1/8-1/4 open and use kick start option.
2. Before using the auto start switch ensure that you press the clutch lever.

- A- Open fuel cock
- B- Switch on ignition
- C- Put gear in neutral position & check neutral indicator is ON.
- D- Pull the choke knob (with cold engine only).
- E- Bring accelerator throttle to idling position
- F- De-clutch
- G- Kick starter pedal or push auto button (for auto start).

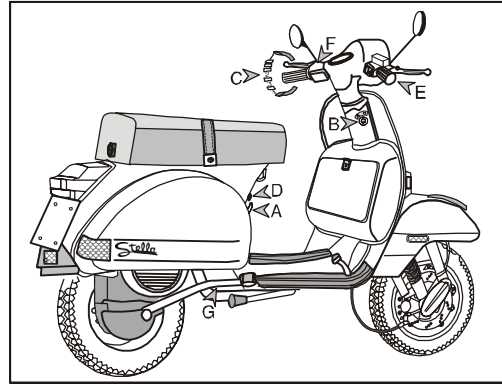

Fig. 22

ENGINE RUNNING-IN

Operation: The most important period in the life of your vehicle is its first 1250 miles. The engine is brand new and different moving parts of the engine need to be set to their correct operating tolerances. This ensures a longer life for your vehicle. It is, therefore, necessary to take some precautions so as not to overload the engine.

Keep to the following speed limits

- 1st Gear : 0 to 6.2 miles/hr.
- 2nd Gear : 6.2 to 12.5 miles/hr.
- 3rd Gear : 12.5 to 21.8 miles/hr.
- 4th Gear : 21.8 miles/hr. and above.

Vary the speed from time to time.

*Do not drive with half, or partially engaged clutch. this will not only damage the clutch, but will also cause the engine to overheat.

*Avoid running the scooter on full throttle for long periods.

*Allow a cooling off period of 5-10 minutes after each hour of use.

*Maintain oil level in gear box up to recommended level.

BATTERY CHECKING :

Battery requires periodic and thorough maintenance as advised below : The level of electrolyte must always be in between the upper and lower levels marked on the battery.

Normally a constant level in the specified range is maintained for about two months or approximately 1250 miles (fig. 23).

The level of electrolyte should be checked once in a month. In case of a normal decrease (0.5 cm) put in distilled water only so as to reach the upper level indicated on the battery. In case of a marked decrease (1 cm or more), please get the battery checked at an authorised Service Station.

Caution:

Battery should be removed if the vehicle is to be washed lying on its side.

Use only 8 Amp. fuse to prevent serious damage to the wiring harness & battery. Ignition switch should be in 'off' position while replacing fuse.

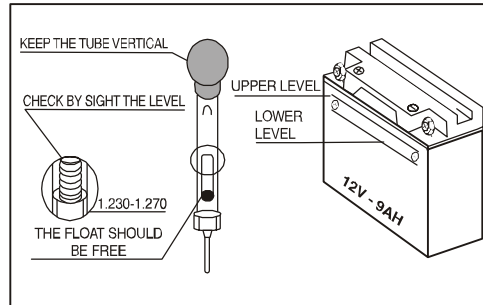
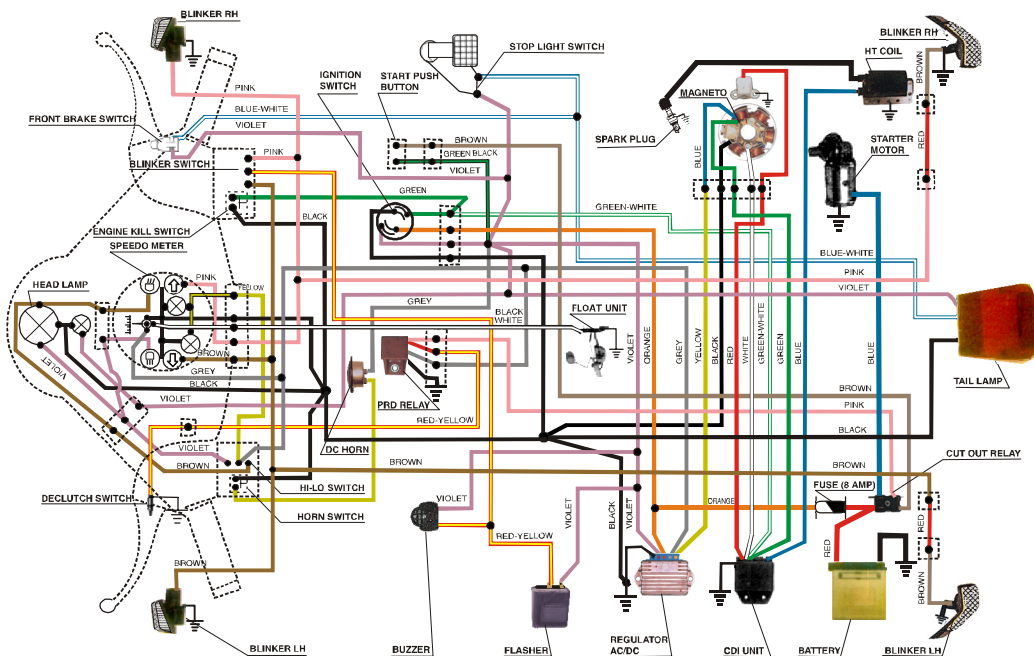

Fig. 23

WIRING DIAGRAM



RECOMMENDED OILS AND LUBRICANTS

S.No.	DESCRIPTION OF PARTS	APPLICABLE LUBRICANTS	RECOMMENDED BRAND OF LUBRICANTS
1.	Clutch & Brake levers	Grease	Automotive/Bearing Grease
2.	Steering Column Bearing	"	"
3.	Front Wheel Bearings	"	"
4.	Speedo Drive Gear	"	"
5.	Front Suspension	"	"
6.	Control Cables	Grease &	"
			"
7.	Gear Control Assy.	Grease	"
			"
8.	Disc Brake	Brake fluid	DOT 4, Mobil Super Heavy Duty
8.	Gear Box *	Oil	SAE 30 Engine Oil
9.	Petrol oil mixture	Oil	Motorcycle-Formulated Two Stroke Oil

* Recommended quantity of oil to be filled in Gear Box is 250 ml + 0ml
- 5 ml

28

REMOVAL AND REFITTING OF COWLS:

The levers for opening the cowls are located under the saddle and can be operated only with the saddle is unlocked and lifted.

For removal of cowls, lift the saddle (as explained on page 18). Pull lever '1' for engine cowl & '2' for spare wheel cowl so that the hook '3' is free from the cowl anchoring. Swing the cowl outwards so that the front locating pin '4' is free from its housing.

Next, lift the cowl upwards from the front pivoting onto its rear section so that the clasp '5' releases from the chassis bracket. Last, pull the cowl outward on pin '6' so that the latter clears its housing, thus releasing the cowl.

For refitting the cowls follow the reverse procedure.

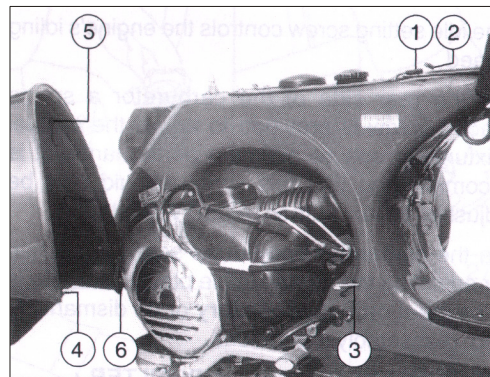

Fig. 25

1. Lever for engine cowl
2. Lever for LH cowl
3. Hook for locking
4. Front locating pin
5. Clasp securing cowl to chassis
6. Rear hooked pivot pin

29

TUNING OF CARBURETOR :

The idle setting screw controls the engine's idling speed.

On the rear side of the carburetor a spring loaded screw is provided to adjust the air fuel mixture. To ensure optimum performance, it is recommended that this screw should only be adjusted by an authorized service station.

On the carburetor body a set screw is applied for adjusting the throttle cable play; this screw is to be reset **only if necessary** or on dismantling and reassembly operations.

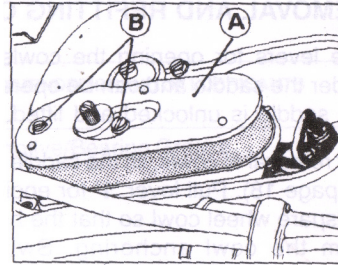

Fig. 26

AIR CLEANER AND AIR FILTER :

AIR CLEANER : For removing the air cleaner 'A' (fig. 26) remove the engine cowl (fig. 25) and air cleaner case cap. Unscrew the two screws 'B' and take out the air cleaner.

Note: When air cleaner case is taken off, the carburetor is accessible.

For cleaning and washing air cleaner use fuel oil mixture.

Air filter: Air filter is fitted over air in-take hole on chassis below dual seat and requires cleaning during each periodical service (fig.27) & more frequently when riding in dusty areas.

30

Procedure for cleaning :

- Lift the seat and take out the air filter by unscrewing it from the support plate.
- Rinse the filter in **kerosene or petrol only** till same is fully cleaned.
- Blow dry the filter with low air pressure.
- Replace the filter ensuring proper positioning of its gasket.

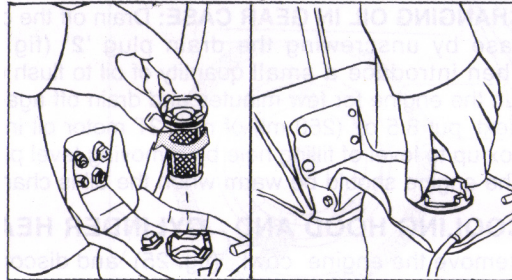

Fig. 27

SPARK PLUG CLEANING:

Disconnect the high-tension (HT) lead cable by removing the suppressor cap from the spark plug.

Wipe & clean the area around the spark plug than remove it with wrench (fig. 28)

Clean the electrodes with a wire brush in pure gasoline (petrol)

Adjust the gap 0.7 - 0.8 mm.

Check porcelain insulation, if cracked or broken change plug. Place spark plug back into position.

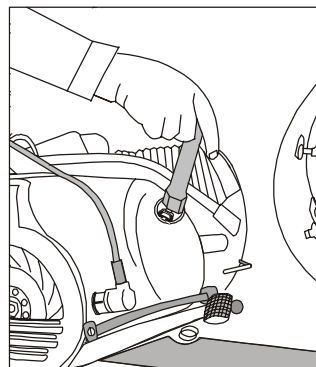

Fig. 28

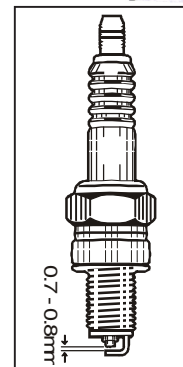

Fig. 29

31

CHANGING OIL IN GEAR CASE: Drain off the crank case by unscrewing the drain plug '2' (fig. 30). Then introduce a small quantity of oil to flush case, run the engine for few minutes and drain off again. Next, put 8.5 oz (250 ml) of new motor oil in gear box up to level of filling hole by removing level plug '1' The engine should be warm when the oil is changed.

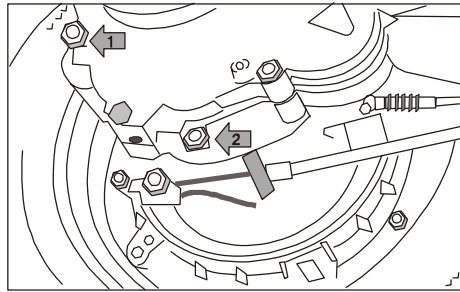

Fig. 30

COOLING HOOD AND CYLINDER HEAD:

Remove the engine cowl, (fig. 25) and disconnect the HT lead, dismantle the 'cooling hood' (fastening 'A'-'B'-'C' fig.31) and unscrew the 4 nuts using the tool kit wrench.

When refitting, tighten the securing nuts alternately.

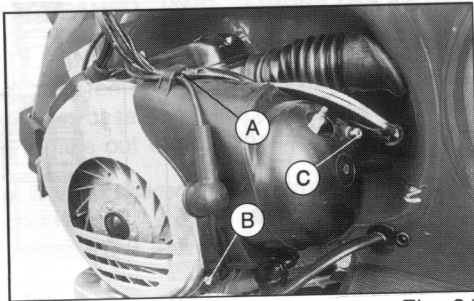

Fig. 31

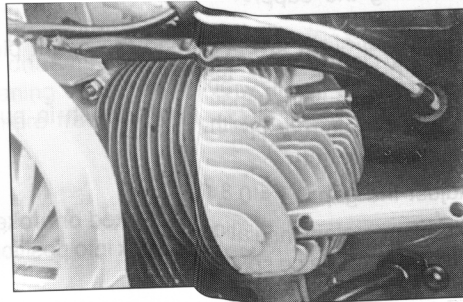

Fig. 32

CHANGING WHEELS & TIRES:

For dismantling the wheels, remove the wheel covers and then the securing nuts (fig. 33 & 34). On reassembly tighten the securing nuts alternately & progressively.

For removing the tires: first deflate them and then remove the nuts joining the two wheel rims.

Check that tires are at the recommended level (page 10) at the nearest service station.

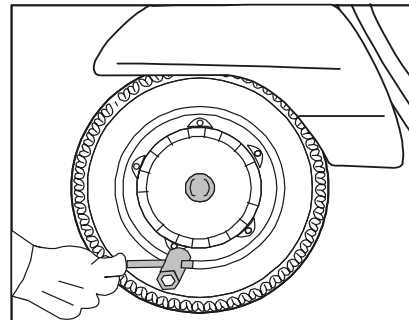

Fig. 33

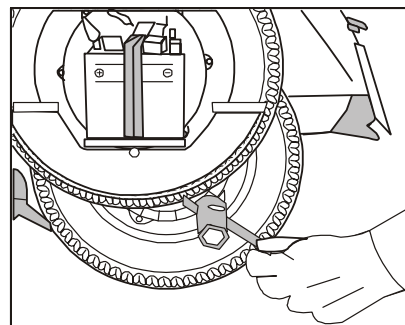

Fig. 34

REMOVING AND REFIXING THE SPARE WHEEL: To remove the spare wheel, first remove the wheel cowl (procedure on page 27.)

Next, unscrew the bolt securing the spare wheel protection cover (fig. 35).

Last, remove the two nuts 'A' which secure the wheel to the upper part of the bracket (fig. 36).

To replace the spare wheel, follow the above procedure in reverse order.

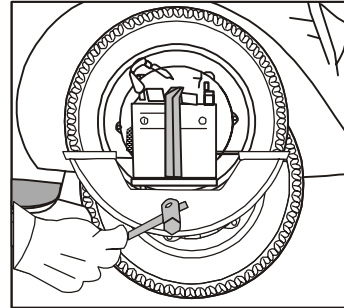

Fig. 35

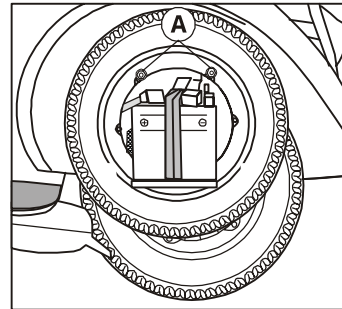

Fig. 36

34

BRAKE ADJUSTMENT:

Adjust the screws as indicated with arrow in fig. 37. Ensure that **the wheels should rotate freely** when the brake lever or pedal are in their resting position.

Note: *The braking action should begin immediately on operating the respective controls.*

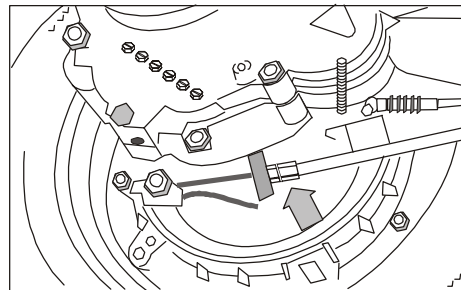

Fig. 37

35

FRONT DISC BRAKE

Stella scooters are produced with a Disc brake in front wheel (Fig. 38). The disc brake functions on hydraulic system. Proper functioning of the brake depends on maintaining the correct level of brake fluid in the 'Master Cylinder Assy.'

Check the level of brake fluid in the Master Cylinder which is located on the RH side of the handle bar (Fig. 39). The transparent level indicator provided in Master Cylinder should never be lower than the 'MIN' mark.

If the fluid level is found low, then add the appropriate brake fluid to the correct level.

Under normal conditions, it is advisable to change the brake fluid every 10,000 miles or every 2 years.

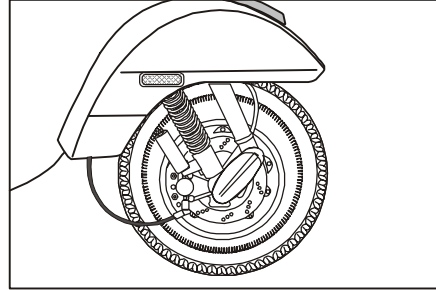

Fig. 38

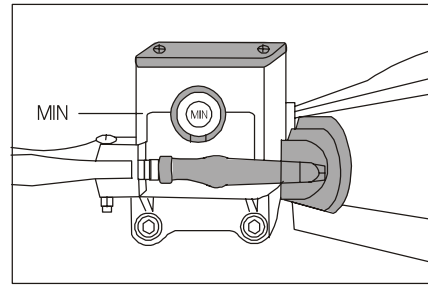

Fig. 39

36

REPLACING BULBS (fig. 40) :

To access the headlamp bulbs, first remove the four screws 'A' from the lower part of the handlebar.

Next, push the speedometer cable upwards & disconnect from the speedometer.

Then, lift cover 'B', disconnect the harness sockets, and remove the handle bar top cover.

Last, take out the bulb holder and replace the bulb.

To reassemble, follow the reverse procedure.

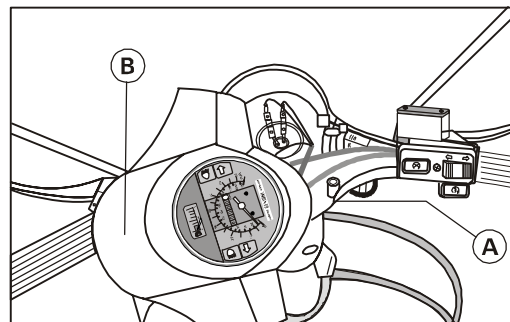

Fig. 40

37

HEAD LAMP SETTING: Place the unloaded vehicle on a level floor at 10 meters from a twilight white screen and take care that the vehicle axis is perpendicular to the screen.

Draw a horizontal line 'b-b' at a height of 'B' from the ground corresponds to 0.9xC with the headlamp switched on the low beam position,

the horizontal line of demarcation between the dark zone and the lighted one should not be over the horizontal line.

Note: The operation of headlamp setting can be carried out also with the driver only sitting on the machine. In this case, of course, the beam alignment should be altered whenever the scooter is being ridden by both driver and passenger.

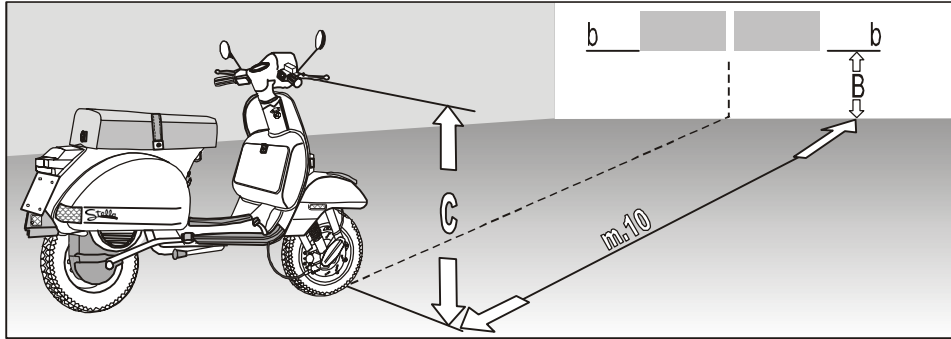

$B=C \times 0.9 - C$ = Height from the ground to headlamp centre. Fig. 41

$B=C \times 0.95$ when the setting of the headlamp is carried out with the vehicle at 5 meters from the screen.

PERIODICAL MAINTENANCE

Preventive maintenance:

In order to optimize Stella's performance, it is important to carry out periodic maintenance. Refer to the following table for suggested action and scheduling for different maintenance matters.

Code of suggested action is:

C - Check

I - Inspect, check and adjust

F - Drain and refill with fresh oil

L - Lubricate

T - Check and top up if necessary

D - Carry out.

S.No.	ITEM	2500 Miles	5000 Miles
1.	Washing and cleaning	D	
2.	Gear oil	F	
3.	Tightening of all external nuts and bolts (Also cylinder head)		D
4.	Spark plug	I	
5.	Air cleaner (cleaning and washing in fuel oil-mixture)	D	

S.No.	ITEM	2500 Miles	5000 Miles
6.	Air filter (outer) washing in kerosene or petrol only	D	
7.	Carburetor tuning	I	
8.	Carburetor cleaning	D	
9.	De-coke of engine and silencer neck		D
10.	Ignition timing		C

S.No.	ITEM	2500 Miles	5000 Miles
11.	Functioning of electrical electronic systems	C	
12.	Battery (Top up, check sp. Gravity and bleeder tube)	D	
13.	Control cable adjustment	I	
14.	Brakes	C	
15.	Clutch	C	

S.No.	ITEM	2500 Miles	5000 Miles
16.	Front and rear shocker		C
17.	Tire rotation		D
18.	Lubricate: Gear control assembly Speedo drive gear Front wheel bearing Steering column bearings	L L	L L

Caution : *Clean Air Filter (located below saddle) more frequently when riding in dusty areas for better performance and longer life of engine. Replace the filter after 6250 miles or earlier, if required.*

40

CLEANING & POLISHING:

BODY WASHING

Painted surfaces should first be wet down using a low-pressure hose to loosen any dirt.

Next, use a car type shampoo (water solution 3-5% weight) and sponge down the surface.

Dry off using a clean chamois leather to eliminate water marks.

Note : *For cleaning the exposed surfaces of the engine use paraffin (for drying up the vehicle use a brush and soft cloth or chamois leather).*

Spots : Possible spots caused by tar, grease, oil etc. can be removed by rubbing gently with a soft cloth or cotton-wool dipped in oil or turpentine.

Rinse the area immediately with a solution of a car type shampoo and plenty of water.

Any insect remnants on the windshield or headlamp can be removed with a combination of warm water and car shampoo.

41

Polishing : In addition to regular cleaning, periodic polishing helps to minimize the effects of sun, rain or dust on the paint.

To Polish your scooter : first apply a thin coat of good quality wax, then polish and shine with a soft cloth. Gently rub the surfaces to be polished in a side to side manner.

Note: *Washing and polishing operations should not be carried out in the sun, particularly during the summer when the bodywork is warm. Under no circumstances should petrol or Diesel oil be used for washing painted surfaces or plastic material as they will deteriorate.*

CARE OF YOUR VEHICLE WHEN NOT IN USE FOR LONG PERIODS :

Store *Stella* properly if you are not going to use her for more than two months.

First, remove (i.e. siphon) the petrol from the fuel tank. Start the engine for some time and burn the remaining petrol.

Next, remove the spark plug (explained on page 29), and put a few drops of 2T oil in the spark plug hole. Press the kick lever a couple of times. Replace the spark plug.

Clean the vehicle thoroughly and apply antirust grease on all unpainted metallic parts.

Remove the battery.

Finally, raise the wheels off the ground using wooden planks, and deflate the tires so that they do not touch the floor. And last, cover the scooter.

42

TROUBLE SHOOTING

Engine fails to start or stops immediately after starting

Possible Cause

Fuel

Fuel cock in OFF position
No petrol in fuel tank
Irregular flow of petrol to the carburettor
Air lock in fuel tank
Dirty carburettor
Carburettor flooded
(presence of unvapourised fuel in the engine cylinder)

Electrical

Ignition off
Spark plug terminal disconnected
Dirty spark plug
Weak spark
Engine Misfires
Irregular flow of fuel to the carburettor

Remedy

Bring the fuel cock to ON position
Refill
Clean fuel lines, fuel cock and filters
Check and clean fuel tank cap air vent hole
Clean carburettor
Close fuel cock, open throttle and kick over the engine several times, or remove the spark plug, clean, kick over the engine several times, refit spark plug and start

Switch on ignition
Connect the terminal properly
Clean and re-set gap
Contact authorised dealer

Check and clean, fuel lines, fuel cock and filters

If the suggested remedies are not sufficient in eliminating the trouble please contact the nearest dealer.

43

TIRE REGISTRATION

Registration form for Independent distributors and dealers-tire identification number

IMPORTANT

Approved through 5-31-85
OMB No. 2127-0050

In case of a recall, we can reach you only if we have your name and address. You **MUST** send in this card to be on our recall list.

A

Do it today.

SHADED AREA MUST BE FILLED IN BY SELLER

	QTY	TIRE IDENTIFICATION NUMBERS										
		1	2	3	4	5	6	7	8	9	10	11
CUSTOMER'S NAME (Please print)												
CUSTOMER'S ADDRESS												
CITY STATE ZIP CODE												
NAME OF DEALER WHICH SOLD TIRE												
DEALER'S ADDRESS												
CITY STATE ZIP CODE												

Genuine Scooter Company and LML Limited have joined forces to produce a world-class Motor scooter specifically for the North American Marketplace. LML Limited is a well-known manufacturer, based in India, of "everyday mobility" that we have been fortunate enough to have as our valued partner. We are proud to present this product, Stella, which they have skillfully manufactured for our customers. We wish you years of pleasurable scootering.

The descriptions and illustrations in this manual are not to be taken as binding on the manufacturer. The essential features of the model described herein remain unaltered, though Genuine Scooters and LML Limited reserve the right to carry out, at any moment, without modifying this booklet, modifications to the machine and its parts or accessories, that the companies deem necessary for improving the machine or satisfying manufacturing standards.

SCOOTER **GENUINE** COMPANY

www.guinescooters.com

Chicago, Illinois USA